



Medical

Adhesives

Enabling Reliable, Multi-Week
Wearable Device Attachment

WHITE PAPER

Abstract / Executive Summary

Innovations in wearable medical products, like the advent of convenient, low-profile continuous glucose monitors (CGMs), are beginning to outpace advances in the adhesive materials that are needed to interface device with body. The promise of sophisticated sensing and/or drug delivery devices, considering the economics involved, cannot be realized without the means to hold them on the skin for weeks at a time. Our objective was to engineer a state-of-the-art adhesive system that offers reliable, multi-week wear times. Sham devices consisting of a plastic disk bonded to a skin adhesive tape in a skirt-style construction were assembled using three different adhesive material combinations. With informed consent, healthy human volunteers were recruited to wear a randomized selection of prototypes on their abdomens and arms, recording the time of application and time of failure, when the prototype eventually detached. Instances of skin irritation and discomfort during wear were also noted throughout the study, which lasted a total of 14 days. Reliability was assessed by analyzing the time to adhesive failure using Kaplan-Meier non-parametric survival analysis. All three prototypes evaluated in this study exhibited excellent reliability and were well-tolerated with minimal irritation or discomfort during wear. The results emphasize the importance of selecting the right adhesive for the right application, and that wear performance is dependent on numerous factors, including target wear time, device design, wear location and skin properties.

Introduction

Real-time sensors allowing for the continuous monitoring of critical biomarkers for medical diagnostics, physiological health and fitness monitoring, and evaluation are common examples of “wearables.”¹ Within the past decade, wearable devices have seen tremendous innovation through advances in sensing electronics, growth in nanomaterials and the evolution of computing software—and they continue to evolve. For example, the size, weight and complexity of CGMs have decreased because of advances in electronics and sensing technologies, which have contributed to increases in the duration of use, data management and user-friendliness.²

One major challenge to advancements in wearable technology is the fact that skin is more of an information barrier than an information source when it comes to sensing.³ Skin is multi-layered, dynamic and produces oils, sweat and hair, all of which affect real-time sensing signals. For these reasons, it also presents a challenge for adhering devices to skin. With the advances of these skin adhering technologies, advancements are needed in the means by which they interface with the body: there is a need for specialized adhesives to attach these devices to skin for weeks at a time. These adhesives which act as the interface between the device and the skin need to allow the sensor to monitor activity without any interference or restriction of the user’s movement. Additionally, quality-of-life requirements are important for device adherence, so these devices also need to be conformable, breathable and comfortable for the user.

MED 5740, MED 5741 and MED 5742 are acrylic skin adhesives designed for long-term wear applications, especially in skin-adhering wearable devices. This evaluation was undertaken to determine and compare wear times of these three acrylic pressure-sensitive adhesives for wearable monitoring devices. Adhesion levels, patient comfort and skin assessments were also evaluated.

Methods

Materials

Three different skin adhesive tapes were evaluated in this study: MED 5740, MED 5741 and MED 5742. Each skin adhesive tape has the same pressure-sensitive acrylic skin adhesive designed for long-term wear; the tapes differ by their carrier. Table 1 and Figure 1 show the physical properties of the tested tapes. Table 2 shows the composition and carriers of the three products.

TABLE 1

TYPICAL VALUES FOR PHYSICAL PROPERTY TESTING				
PROPERTY	TDS TEST METHOD	MED 5740	MED 5741	MED 5742
PEEL ADHESION ON POLYETHYLENE (PE) [LBF/IN]	TDS-01	0.7	0.6	1.1
PEEL ADHESION ON STAINLESS STEEL (SS) [LBF/IN]	TDS-04	1.8	1.4	5.2
QUICK STICK ADHESION ON STAINLESS STEEL (SS) [LBF/IN]	TDS-05	1.4	0.7	3.1
90 DEGREE LINER RELEASE [GF/2IN]	TDS-06	150	150	120
STATIC SHEAR [MINUTES]	TDS-12	350	150	1000
MOISTURE VAPOR TRANSMISSION RATE (MVTR) [G/M ² *24HR]	TDS-16	400	1040	270

FIGURE 1

SPIDER CHART COMPARING THE PHYSICAL PROPERTIES OF THE ADHESIVES

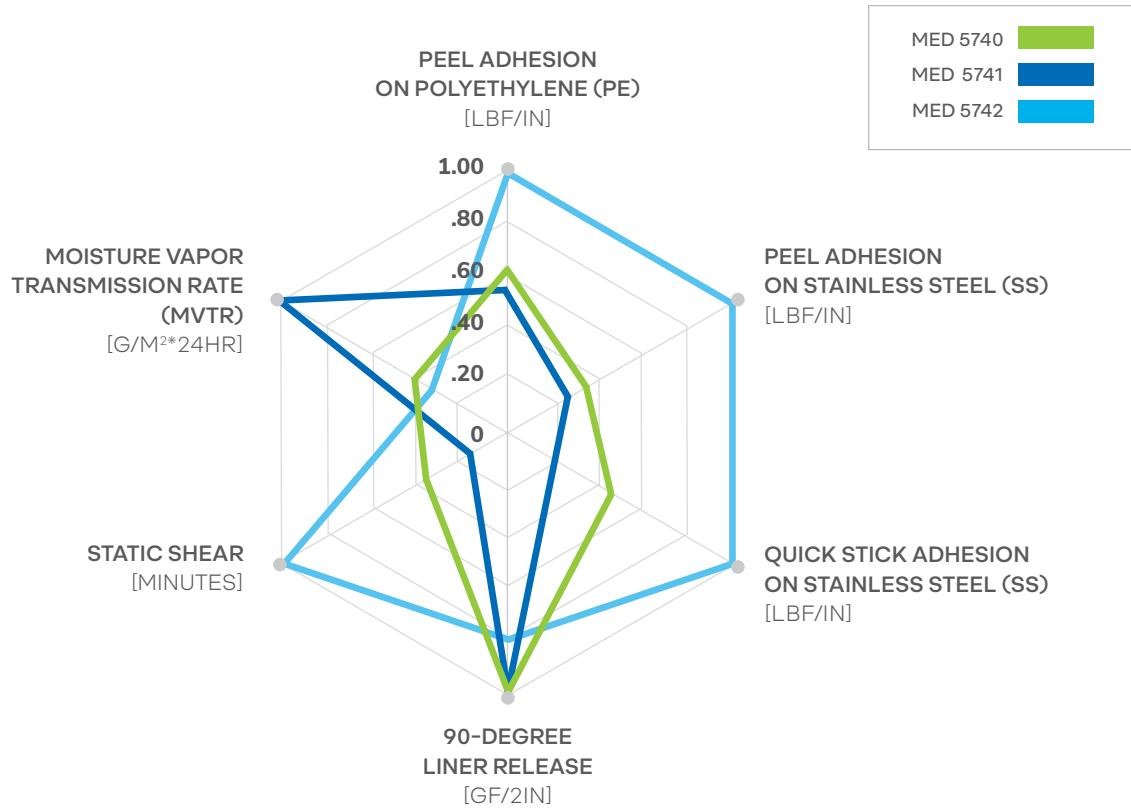

TABLE 2

COMPOSITION AND CARRIERS OF ADHESIVES

	MED 5740	MED 5741	MED 5742
CARRIER	WHITE THERMOPLASTIC POLYURETHANE NONWOVEN	WHITE POLYESTER (PET) NONWOVEN	1 MIL CLEAR POLYURETHANE FILM
ADHESIVE	60 G/M ² I-785	60 G/M ² I-785	60 G/M ² I-785

Methods (continued)

These three skin adhesive tapes were tested in a wear application with sham devices (Figure 2). Each sham device was an island-placed sham device bound to the skin adhesive patch with a tie layer construction tape. This configuration mirrors the wear characteristics and designs of commercially available wearable devices, such as CGMs.

Prototype 1 This prototype has [MED 5740](#) for the skin adhesive layers

Prototype 2 This prototype has [MED 5741](#) for the skin adhesive layers

Prototype 3 This prototype has [MED 5742](#) for the skin adhesive layers

FIGURE 2

ILLUSTRATION OF THE PROTOTYPICAL WEARABLE DEVICES EVALUATED IN THIS STUDY

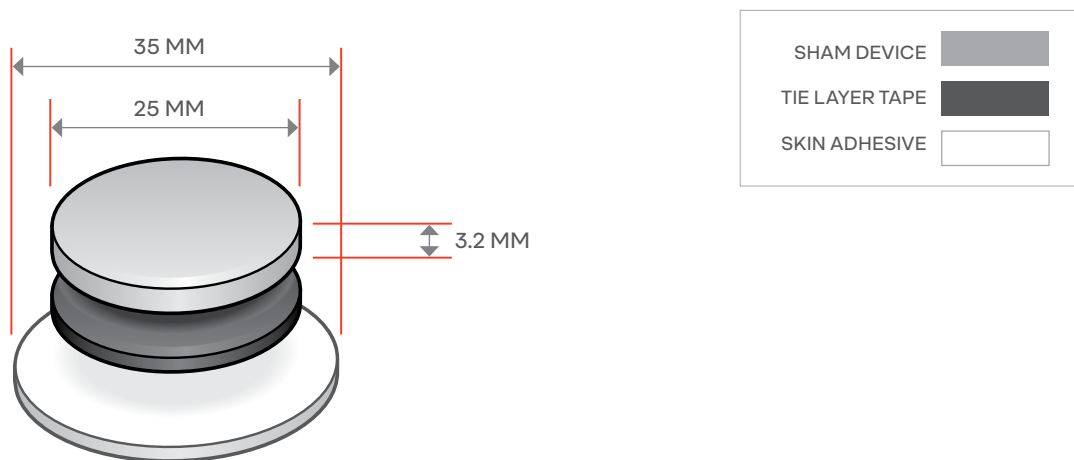

Methodology

The study was conducted in a single center on healthy human volunteers. Each participant's consent was obtained prior to enrollment in the study. All skin contacting tapes were tested for and passed biocompatibility testing per ISO 10993.

Eligibility criteria Subjects were screened by pre-determined inclusion and exclusion criteria. The inclusion criteria were: i) Adults of at least 18 years of age and in good health, ii) willing and able to follow study directions, iii) willing to refrain from taking showers or engage in strenuous physical activity for at least 3 hours after the devices are applied to the skin, and iv) agrees to visit the Researcher periodically throughout the study for performance assessments. Exclusion criteria were: i) pregnant women, ii) acute or chronic illness, iii) immunocompromised subjects, iv) use of any prescribed anti-inflammatory drugs, immunosuppressive drugs or antihistamine medication, v) current participation in any other clinical testing or investigational drug study, vi) allergy to adhesives or bandages, and vii) damaged skin in or around test sites.

Enrollment and application site preparation Subjects were asked to visit the research facility on Day 0, Day 7 and Day 14. On the day of application (Day 0), subjects' skin was assessed to ensure compliance with the eligibility criteria, and the hair on the test sites was clipped to allow for adherence of the samples to the skin. The subjects wore 3 variants of the prototypical wearable device for up to 14 days. Devices were worn on the back of the arm and on the lower abdomen to mirror application locations characteristic of wearable devices. Prior to the application of the devices, the skin of the test sites was cleaned with alcohol wipes (70% isopropanol) and left to dry for at least 2 minutes. Prototypes were labeled with test article identification codes for tracking the location of device placement and prototype identity. Placement of the prototypes was randomized such that the prototypes were equally distributed over the two test locations across the participant pool.

Assessments Subjects were asked to wear the prototypes for a period of 14 days. Subjects were allowed to shower and exercise normally; moisture exposure was not limited. The researcher performed weekly visual assessments of the prototypes using quantitative grading scales, assessing the following characteristics:

- Percentage of the skin adhesive patch still adhered to the skin
- Appearance of the prototypes, including visual assessments of adhesive residue
- Subject comfort (itchiness and irritation assessments)

The subjects reported the day and time when the prototypes detached from the skin to the researcher. Total wear times were calculated for each prototype for each subject. Where a prototype had fallen off prior to Day 14, the date, time and conditions under which the prototype detached from the skin were documented by the researcher. Total elapsed wear times were calculated for each prototype based on the best available information documenting the removal time. Total wear time was defined as the elapsed time from when the prototype was applied until it became detached from the skin, either intentionally or unintentionally.

Statistical analysis Data were tabulated and basic summary statistics (mean and 95% confidence intervals) were calculated. Survival analysis was conducted using Minitab® statistical software (Minitab, LLC, version 16.2.4). Non-parametric Kaplan-Meier technique was used to generate survival curves from the available data.

Results

Twenty subjects were enrolled in and completed the study. All subjects wore their prototypes until they fell off unintentionally or until the completion of the wear period. None of the subjects intentionally removed their prototypes because of skin irritation or any other reason.

Wear times The total number of days each variant was attached to the test sites was computed as the elapsed time between the device application and removal (Figure 3). Pairwise comparison between the survival curves showed no statistically significant differences (MED 5740 vs. MED 5741, $p > 0.05$; MED 5740 vs. MED 5742, $p > 0.05$; MED 5741 vs. MED 5742, $p > 0.05$).

Adhesion levels There were no statistically significant differences in performance for the three long-term-wear skin adhesive tapes. The three prototypes all displayed excellent multi-week wear and reliability, with no adhesive failures until the tenth day of wear.

Patient comfort Through 14 days, all participants (100%) reported no itching, irritation or any other discomfort at any point of time during the study duration.

Prototype location Prototypes were randomized across two sites on the body representing typical locations for wearable devices. Wear performance varied across the two locations for each prototype, but there were no statistically significant differences in performance.

FIGURE 3

SURVIVAL CURVES ILLUSTRATING THE PERCENTAGE OF DEVICES THAT REMAINED ADHERED AS A FUNCTION OF THE DURATION OF WEAR TIME AND THE COMPUTED 95% CONFIDENCE INTERVALS

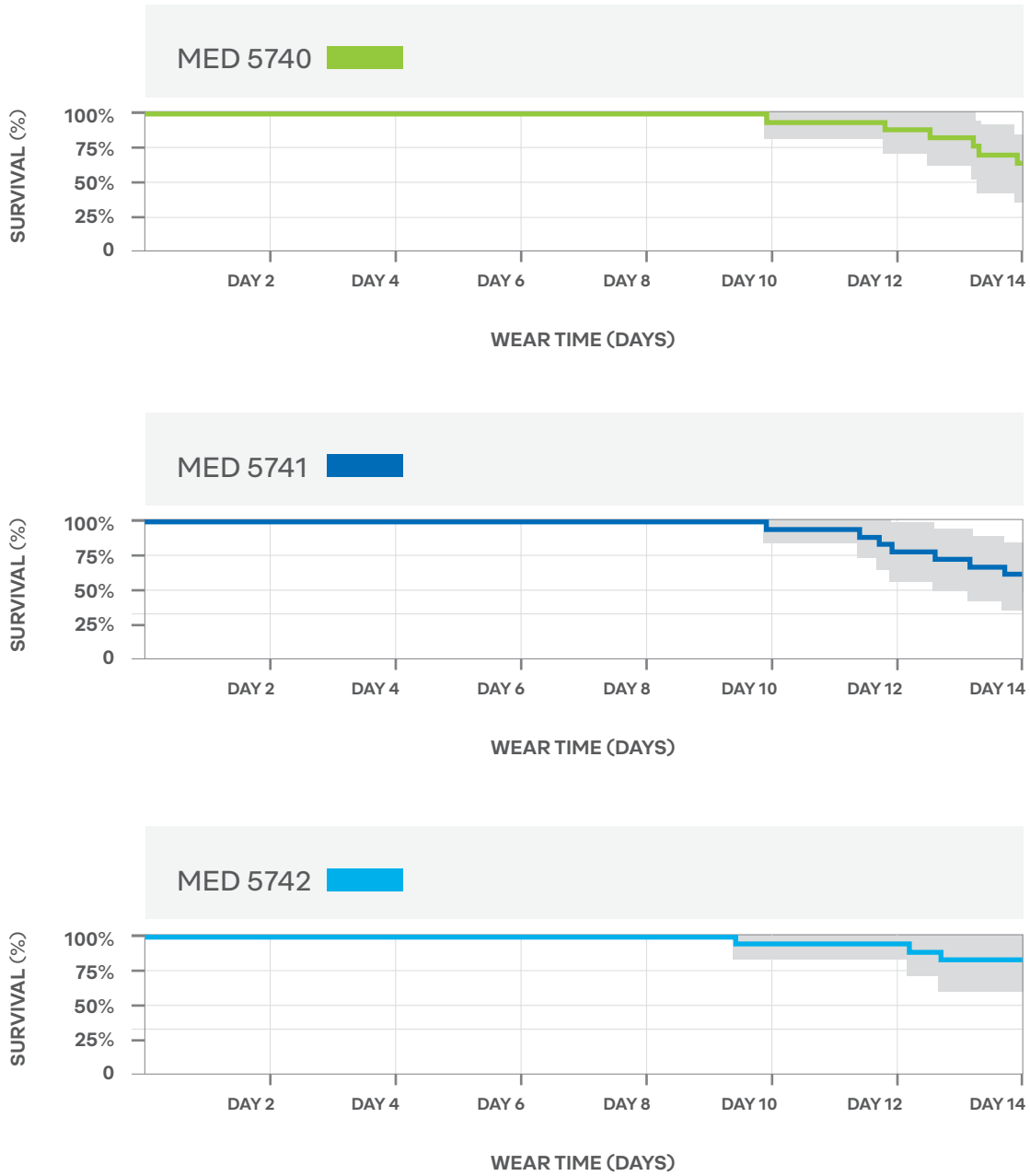

Discussion

Understanding the science of skin, the design of the wearable device and the device use case is critical in selecting the right adhesive for a medical device. Choosing the right level of adhesion is particularly important for skin-contacting medical devices because there is a need to balance secure attachment with easy removal because inappropriate selections could lead to adhesion failure, skin injury and/or device malfunction.

Skin adhesives MED 5740, MED 5741 and MED 5742 are single-coated tapes with a medical grade adhesive optimized for long-term wear applications. The tapes differ only in their carrier: MED 5740 has a white thermoplastic polyurethane nonwoven carrier, MED 5741 has a white polyester spunlace nonwoven carrier and MED 5742 has a clear polyurethane film carrier. All three tested skin adhesives are commercially available products. This report presents the findings of a direct comparison of these three skin adhesives in a simulated wear application to characterize the products' wear performance.

In this evaluation of three pressure-sensitive acrylic adhesives in a prototypical wear application, we show that all three products demonstrated excellent reliability (no failures until the tenth day of wear) and strong adhesion on skin through 2 weeks of wear. Participants found the prototypes to be comfortable, and none reported itching, irritation or any other discomfort at any point during the study. From the point of view of product acceptance, all three skin adhesives performed very well and displayed their success in multi-week wear applications.

The results of this study highlight the importance of adhesive selection for wearable devices. MED 5740, MED 5741 and MED 5742 have distinct physical properties (Figure 1 and Table 1) when tested in a laboratory setting. The products differed in breathability, adhesion levels and elasticity of the carriers, yet they performed equivalently in a study mirroring a real wear application. The study showcases the significance of evaluating adhesives in a wear application on human skin.

Testing on substrates such as stainless steel and high density polyethylene is beneficial because the surfaces are consistent and the testing is reproducible. Skin, however, is complex and dynamic and varies from person to person. Skin produces sweat, oil and hair, all of which impact adhesion to skin; and it is elastic and extensible, demanding an adhesive that can deform with its movements. Skin is multi-layered and constantly changing—old cells from the skin surface are shed as new cells are produced in the underlying epidermis of the skin and pushed to the surface. For these reasons alone, skin as a substrate is very difficult to duplicate under laboratory testing and presents a unique challenge for wearable devices requiring extended wear times. Additional considerations—including the size and shape of the wearable device, the intended wear time, the wearable location and the skin condition—are critical to understand early in the development process for determining the right adhesive for wearable medical devices. While the results from this study demonstrate that MED 5740, MED 5741 and MED 5742 display excellent multi-week wear, the wear time for these products could extend beyond two weeks based on wear conditions, the user environment and product design.

Conclusion

With the right design, adhesive tapes can provide multi-week wear times. These materials open the door for innovative wearable device technologies that are more convenient, comfortable and economical for the patients who use them.

References

- 1 Guk K, Han G, Lim J, Jeong K, Kang T, Lim EK, Jung J. Evolution of wearable devices with real-time disease monitoring for personalized healthcare. *Nanomaterials* 9: E813. (2019)
- 2 Rodbard D. Continuous glucose monitoring: a review of successes, challenges, and opportunities. *Diabetes Technol Ther* 18(Suppl 2):S23–S213. (2016)
- 3 Heikenfeld J et al. Wearable sensors: modalities, challenges, and prospects. *Lab Chip* 18, 217–248. (2018)

CONNECT WITH US FOR MORE INFORMATION



US +1 440 534 2600 MON-FRI, 8AM-5PM ET
INTERNATIONAL +32 14 40 48 11



email **medical@averydennison.com**



website **www.medical.averydennison.com**